

HOFGAS[®] - Smarty

The Compact Mobile Degassing Plant

The compact unit **HOFGASⁱ - Smarty** is a ready-to-fit degassing plant. The unit is equipped for safe and reliable degassing of small and medium size landfills.

Thanks to the simple construction design the **HOFGASⁱ - Smarty** is also suitable for determining the gas production from larger landfills.

All components are mounted compactly onto the robust skid. That way the plant remains mobile. The unit is operated by a relay controller.

With separate adjustable primary and secondary air supply, the combustion can be adapted to the respective operating conditions. The burner and the mixing pipe can be removed without disassembling the combustion chamber.

Once the plant is erected on a concrete or gravel foundation the **HOFGASⁱ - Smarty** is ready to operate.

Mobile and compact degassing system for simple requirements.



HOFGASⁱ - Smarty 300

- ✓ Easy to install
- ✓ Easy to operate
- ✓ Low operating cost
- ✓ Controlled semi-enclosed combustion
- ✓ Turn down ratio 1 : 5
- ✓ Robust construction
- ✓ Available at short notice

General specifications

Gas flow rate	100 - 400	Nm ³ /h
Burner capacity max.	2'200	kW
Blower pressure rise max.	145	mbar
Methane concentration	25 - 55	vol. %
Combustion temperature	700 - 850	°C
Turn down ratio	1 : 5	

Safety features

- EEx motor
- Flame arrester
- Slam shut valve
- Temperature monitoring with shutoff when overheating
- Burner control with UV detection

Site preparation

- Foundation
- Electricity supply
- Gas pipeline connection
- Condensate outlet

Options

- Dewatering lance
- Frost protection
- Explosion proof execution
- Measuring instruments

More options are available on request

HOFGAS[®] - Smarty

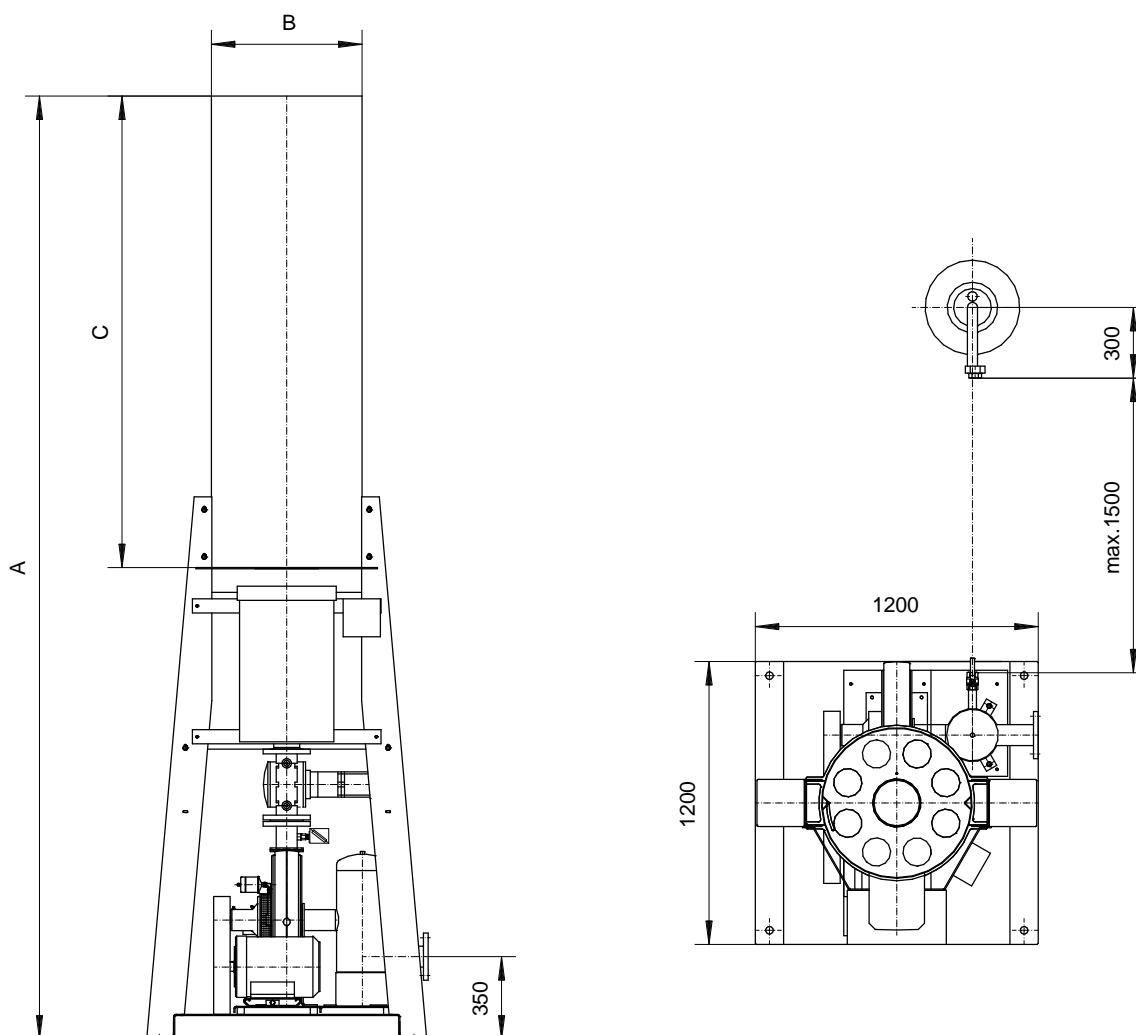

Specification for standard units

HOFGAS ⁱ -	Gas flow rate (max.)	Burner capacity (max.)	Flange connection	Power of el. motor	Fuse protection	Suction pressure	Blower pressure rise	Expected sound pressure level	Dimension A	Dimension B	Dimension C	Weight (approx.) kg
	Nm ³ /h	kW	DN/PN	kW	A	mbar	mbar	mm	mm	mm	mm	
<i>Smarty 100</i>	100	500	80/16	4	16	-60	145	67	4'450	Ø 640	2'000	570
<i>Smarty 300</i>	300	1'500	80/16	5.5	20	-60	145	68	4'450	Ø 640	2'000	570
<i>Smarty 400</i>	400	2'000	80/16	5.5	20	-60	145	69	4'450	Ø 640	2'000	570